

## BLA21-12U-A02/AB2 Technical Specification

This product is a compact servo motor featuring high torque, IP67-rated, and a long-life.

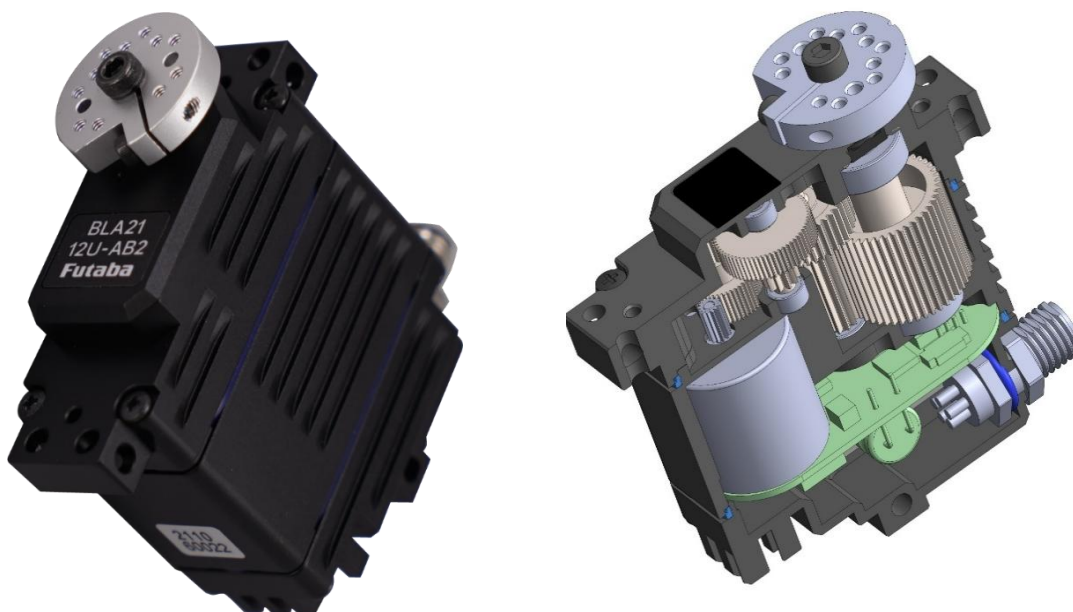

Model	Features
BLA21-12U-A02	Supports DroneCAN v1 signals. Case shielded line and Battery line(-) are separated. No PWM.
BLA21-12U-AB2	Supports DroneCAN v1 and PWM signals. Case shielded line and Battery line(-) are common. No Case shield.

### ■Caution

- This product **SHOULD NOT** be used for the devices that is directly related to human life.
- The application of this product as a weapon of mass destruction is banned, and for military use, it is confined to defense purposes in regions with no security risks.
- Keep the servo away from an object which produces a strong magnetic field.  
There is a possibility of malfunction if the servo is affected by a strong magnetic field.
- Specifications and appearance of hardware/software and accessories are subject to change without notice for improvement.
- When disposing of this product, please comply with the relevant laws and regulations of each country and dispose of it as industrial waste.
- Do not insert or remove connectors while the power is on. Always turn off the power before connecting or disconnecting any connector.
- If you use this product in a vibrating environment, please check the connectors regularly to ensure they have not become loose.

## Basic specifications

Item		Specification			Remarks		
Rated Voltage	typical	12.0			V	DC power supply.	
	range	11.1	~	14.8	V	DC power supply.	
Operating Voltage		9.0	~	16.8	V	DC power supply.	
Standby Current		≤ 55			mA	at 12.0V	
Starting Current <sup>*1</sup>	Design value	≤ 10			A	at 12.0V	
		7			A	100% of torque control. See each signal specification.	
Consumption Current <sup>*1,*2</sup>		120			mA	at 12.0V , No-load	
Max Torque <sup>*1,*2</sup>		4.90			N·m	Applying this torque value for more than 1 second may cause damage.	
		50.0			kgf·cm		at 12.0V
		693.9			ozf·in		
		4.71			N·m		at 11.1V
		5.10					at 14.8V
Rated Torque <sup>*1,*2</sup>		1.47			N·m	Please use at or below this torque.	
		15.0			kgf·cm		at 12.0V
		208.2			ozf·in		
		1.36			N·m		at 11.1V
		1.47					at 14.8V
Rotation Time <sup>*1</sup>		0.09			s/60°	at 12.0V	
		0.10				at 11.1V	
		0.07				at 14.8V	
Speed with no load <sup>*1,*2</sup> (Angle control mode)		667			°/s	at 12.0V	
		111			min <sup>-1</sup>		
Speed with no load <sup>*1,*2</sup> (Speed control mode)		111			min <sup>-1</sup>	at 12.0V	
Rotation Angle <sup>*1</sup>	Range	Mechanical	179.9 ~ -180.0		°	Absolute	
		Software	-	36,000,000 ~		°	Pseudo absolute *Incremental above mechanical range.
	+		36,000,000				
	Accuracy	±3.0			°	Standard value	at 12.0V, No- Load, Position:±60°
±1.5			Measured value				
Direction <sup>*1</sup>		CW : Rotation Angle > 0 (+) CCW : Rotation Angle < 0 (-)			Based on the top surface of the servo (the side with the nameplate).		
BackLash <sup>*1</sup>		≤ 0.50			°		
Temperature Range	Operating	-40	~	70	°C	-40 °F ~ 158 °F	
	Storage	-40	~	80	°C	-40 °F ~ 176 °F	
Over heat protection		80			°C	The default temperature to activate the self-protection function "Torque OFF" in order to prevent overheat. The temperature can be set from 20° C to 80°C on the Signal line <sup>※3</sup> and on the program tool additionally provided by Futaba.	
		176			°F		

\*1 At 23±5°C (Initial Performance Data)

\*2 Each value is typical.

\*3 The signal used for configuration varies depending on the model.



# Outer Dimension

( unit : mm )

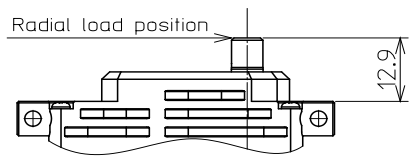
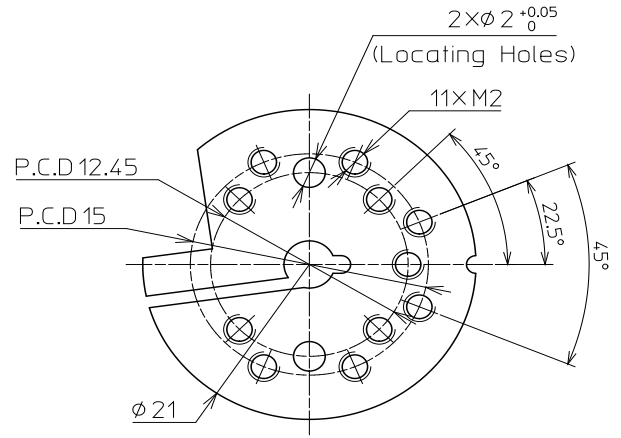
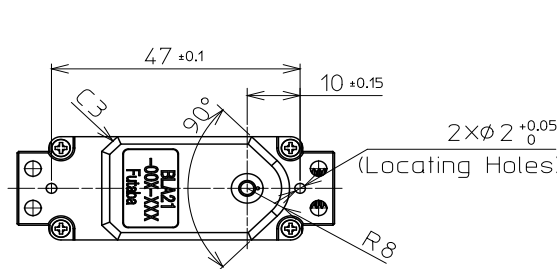
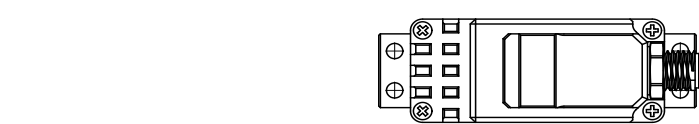
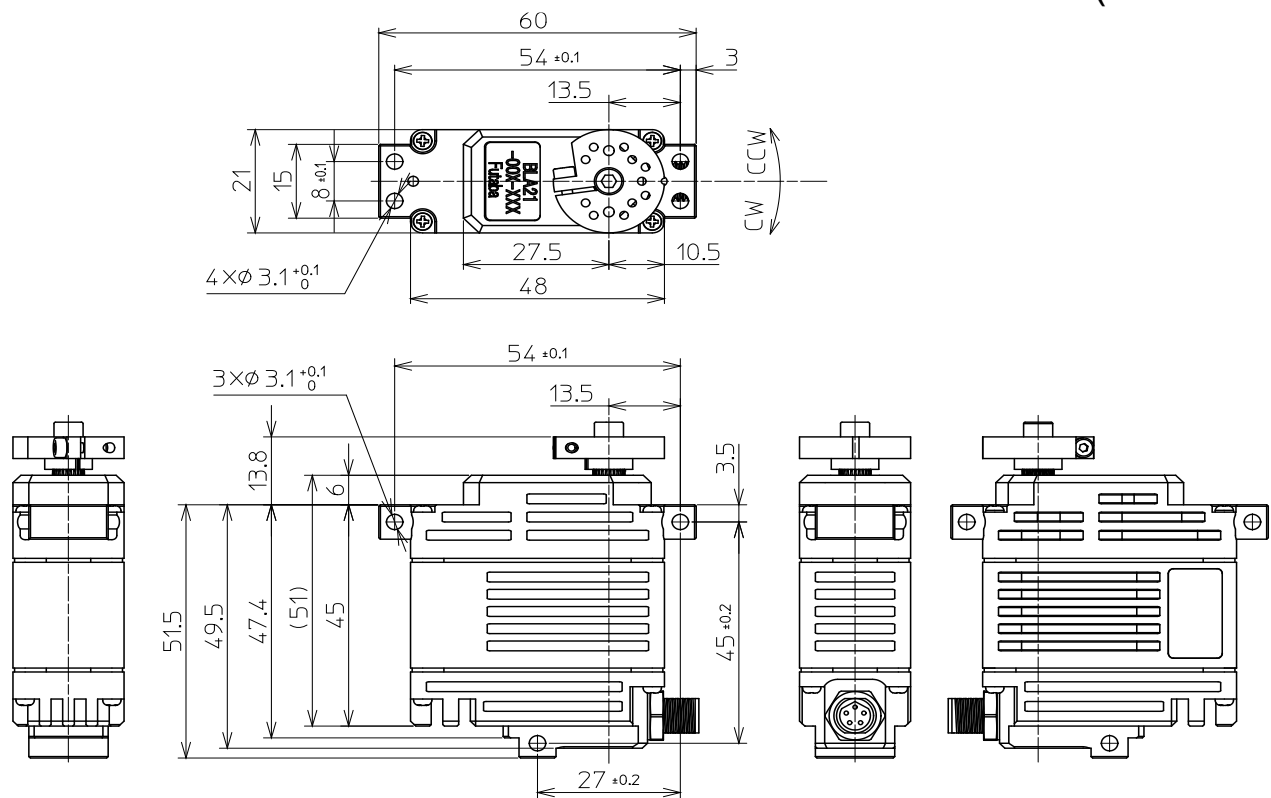

Without Servo Horn

Servo Horn

## OUTPUT SHAFT

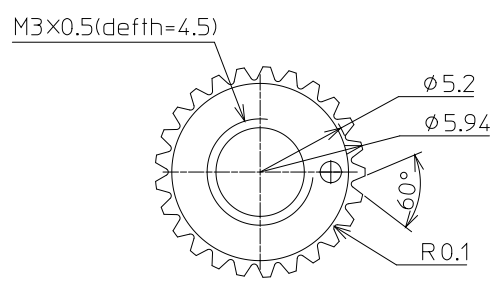
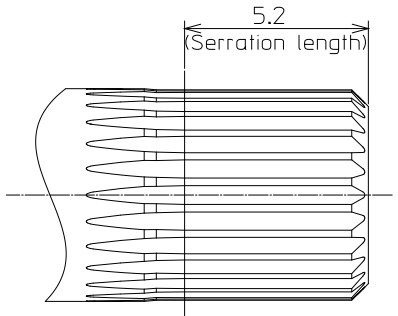

### Sarration Size

- Standard Diameter : ∅6
- Angle : 60°
- Tooth : 25

# Specifications for PWM signals

Item		Specification			Remarks		
Communication Interface				Signal Voltage HIGH:V	max	2.0	V
				Signal Voltage LOW:V	min	5.0	V
				Signal Voltage HIGH:V	max	0.0	V
				Signal Voltage LOW:V	min	0.45	V
				Frame Rate:T	14.25		ms
Pulse Wide:Td	CW	2,120		μs			
	Center	1,520					
	CCW	920					
<p>If the high level voltage exceeds 2.0V, the servo may be damaged.                      If you use an RC device as a signal source, please pay attention to the voltage level of the PWM signal.</p>							
Operating Mode (PWM) + :CW - :CCW (Turn direction reversible) <sup>*1</sup>	Angle control (Absolute)	Rotation Angle	Default	Max	2,120μs	The travel ends are ±60° (default) with a pulse of 1,520 ± 600μs, where the input width is 600μs centered at a neutral of 1,520μs. The travel ends can be adjusted from ±60° to ±180° using the CANBUS line and the Futaba program tool. Both the neutral (1,520μs) and input width (600μs) can be set within ranges of 100 to 10,000μs and 10 to 10,000μs, respectively.	
			+60.0°	+180.0°			
			Neutral 0°				1,520μs
			-60.0°	-180.0°			920μs
	Angle control (Extended)	Rotation Angle	+360.0°		2,120μs		
			Neutral 0°		1,520μs		
			-360.0°		920μs		
	Speed control	Max Speed	+600	min <sup>-1</sup>	2,120μs		
			0		1,520μs		
-600			920μs				

\*1 Based on the top surface of the servo(the side with the nameplate).

## Specifications for CAN BUS signals

Item		Specification				Remarks		
Communication Interface		CAN BUS				Protocol :	DroneCAN v1	
						Baud Rate :	1	Mbps
						Sample Point:	87.5	%
						NodeID:	1	~
Operating mode (CAN BUS)	Angle control (Absolute)	-180.0	~	+179.9	°	The position within this range is absolute and can be recognized by the servo even after power-off. The position commands within this range are uniquely identified. For accuracy, see "Speed with no load (Speed control mode)". Resolution is 0.1°.		
	Angle control	-36,000,000.0	~	+36,000,000.0	°	The servo can accept position commands over 360°, but will lose multi-turn information when switched off, recognizing only the absolute position within 360°. Resolution is 0.1°.		
	Speed control	-300	~	+300	min <sup>-1</sup>	This mode is for continuous servo rotation, with speeds ranging within 300min <sup>-1</sup> . Speed settings can be adjusted via CANBUS and a Futaba program tool. Refer to "Speed with no load (Speed control mode)" for actual speed details.		
	Torque control	-100	~	+100	%	Maximum torque at 12.0V supply voltage is 100%. Refer to "Max Torque".		

# Connector specifications

Item		Specification		Remarks	
Cable		Shielded Cable(Detachable)		400	mm
				15.75	inch
Cable bending radius		78	mm		
Connector	Manufacture	ODS Electronics Co., Ltd.			
	Type	MMEPM05MCC-SHS7001			
	Matching	BE0010 or BE0011		Futaba Support Product Code	
Pin Assignment (BLA21-12U-A02)		Pin No.	Assignment	Cable Color	BLA21-12U-AB2 Pin Assignment
		①	Battery(+)	Brown	Battery(+)
		②	Battery(-)	White	PWM
		③	CAN-H	Blue	CAN-H
		④	CAN-L	Black	CAN-L
		⑤	Case Shield Line	Drain	Battery(-) and Case Shield Line
Pin Layout		<p>The diagram shows a top view of a hexagonal connector with five pins arranged in a circle, numbered 1 through 5. Pin 1 is at the top, 2 is at the bottom, 3 is on the left, and 4 is on the right. Pin 5 is in the center. A side view shows the threaded part of the connector with a length of 10.0 mm and a thread specification of M8*1.0.</p>			

## Model name system

