

記号	訂正記事	担当	日付	仕上	面取
①				FINISH	C.R
②				処理	
③					
④				熱処理	

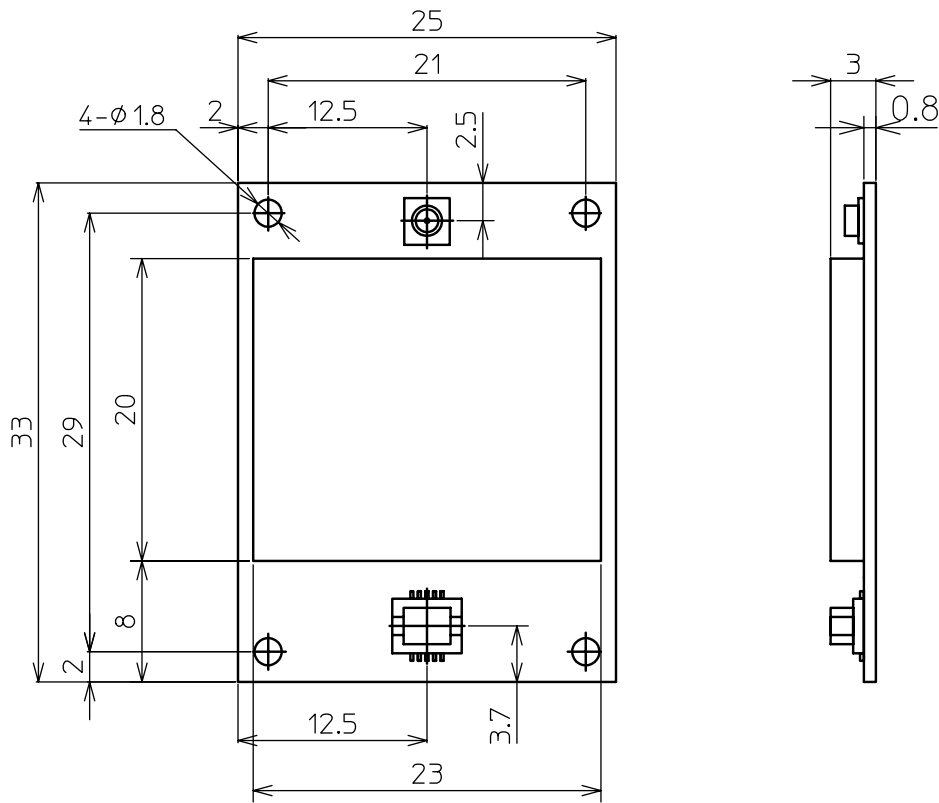

注1) 寸法は参考値とする。

<table border="1"> <tr> <th>公差区分</th> <th>精級 ±</th> <th>中級 ±</th> <th>粗級 ±</th> <th>三角法</th> </tr> <tr> <td>1~4</td> <td>0.05</td> <td>0.1</td> <td>0.3</td> <td rowspan="5"> </td> </tr> <tr> <td>4~16</td> <td>0.07</td> <td>0.2</td> <td>0.5</td> </tr> <tr> <td>16~63</td> <td>0.1</td> <td>0.3</td> <td>0.7</td> </tr> <tr> <td>63~250</td> <td>0.2</td> <td>0.5</td> <td>1.2</td> </tr> <tr> <td>250~1000</td> <td>0.3</td> <td>0.8</td> <td>2.0</td> </tr> </table>	公差区分	精級 ±	中級 ±	粗級 ±	三角法	1~4	0.05	0.1	0.3		4~16	0.07	0.2	0.5	16~63	0.1	0.3	0.7	63~250	0.2	0.5	1.2	250~1000	0.3	0.8	2.0	材質	材厚	個数	尺度	名称 NAME	FDP01TJ010 外觀図
	公差区分	精級 ±	中級 ±	粗級 ±	三角法																											
	1~4	0.05	0.1	0.3																												
	4~16	0.07	0.2	0.5																												
	16~63	0.1	0.3	0.7																												
63~250	0.2	0.5	1.2																													
250~1000	0.3	0.8	2.0																													
設計	製図	検図	承認	日付	2006.9.21																											
					部品番号 PART NO																											
					図番 DWGNo	1M70A842																										