

## BLA21-28U-A02/AB2 Technical Specification

This product is a compact servo motor featuring high torque, IP67-rated, and a long-life.

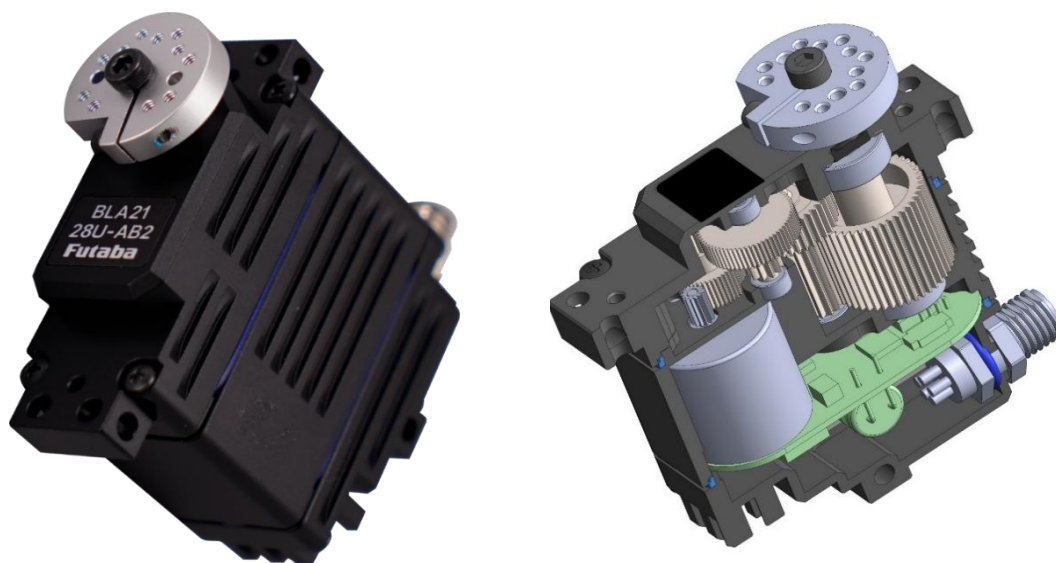

Model	Features
BLA21-28U-A02	Supports DroneCAN v1 signals. Case shielded line and Battery line(-) are separated. No PWM.
BLA21-28U-AB2	Supports DroneCAN v1 and PWM signals. Case shielded line and Battery line(-) are common. No Case shield.

### ■ Caution

- This product must not be used in life-support or other safety-critical devices.
- This product must not be diverted to weapons of mass destruction.
- Any military use of this product is restricted to defensive purposes.
- Keep the servo away from an object which produces a strong magnetic field.  
There is a possibility of malfunction if the servo is affected by a strong magnetic field.
- Specifications and appearance of hardware/software and accessories are subject to change without notice for improvement.
- When disposing of this product, please comply with the relevant laws and regulations of each country and dispose of it as industrial waste.
- Do not insert or remove connectors while the power is on. Always turn off the power before connecting or disconnecting any connector.
- If you use this product in a vibrating environment, please check the connectors regularly to ensure they have not become loose.

## Basic specifications

Item		Specification				Remarks			
Rated Voltage	typical	28.0			V	DC power supply.			
	range	24.0	~	28.0	V	DC power supply.			
Operating Voltage		20.0	~	32.0	V	DC power supply.			
Standby Current		≤ 42			mA	at 28.0V			
Starting Current <sup>*1</sup>	Design value	≤ 5			A	at 28.0V			
		BLA21-28U-A02: 3.2 BLA21-28U-AB2: 2.4			A	100% of torque control. See each signal specification.			
Consumption Current <sup>*1,*2</sup>		80			mA	at 28.0V , No-load			
Max Torque <sup>*1,*2</sup>	4.51			N·m	at 28.0V	Applying this torque value for more than 1 second may cause damage.			
	46.0			kgf·cm					
	638.7			ozf·in					
	4.31			N·m	at 24.0V				
	4.71				at 32.0V				
Rated Torque <sup>*1,*2</sup>	1.47			N·m	at 28.0V	Please use at or below this torque.			
	15.0			kgf·cm					
	208.2			ozf·in					
	1.36			N·m	at 24.0V				
	1.47				at 32.0V				
Rotation Time <sup>*1</sup>	0.07			s/60°	at 28.0V	This unit is commonly used as the speed unit for RC servos.			
	0.08				at 24.0V				
	0.06				at 32.0V				
Speed with no load <sup>*1,*2</sup> (Angle control mode)		857			°/s	at 28.0V			
		143			min <sup>-1</sup>				
Speed with no load <sup>*1,*2</sup> (Speed control mode)		143			min <sup>-1</sup>	at 28.0V			
Rotation Angle <sup>*1</sup>	Range	Mechanical	-180.0	~	179.9	°	Absolute		
		Software	-	36,000,000 ~			°	Pseudo absolute *Incremental above mechanical range.	
	+		36,000,000			°			
	Accuracy	±3.0			°	Standard value	at 28.0V, No- Load, Position:±60°		
±1.5			Measured value						
Direction <sup>*1</sup>		CW : Rotation Angle > 0 (+) CCW : Rotation Angle < 0 (-)				Based on the top surface of the servo (the side with the nameplate).			
BackLash <sup>*1</sup>		≤ 0.50			°				
Temperature Range	Operating	-40	~	70	°C	-40 °F ~ 158 °F			
	Storage	-40	~	80	°C	-40 °F ~ 176 °F			
Temperature Protection		Low		High		The default temperature to activate the self-protection function "Torque OFF". The temperature can be set within the product specification range using the program tool provided separately by Futaba.			
		under	-40	°C	over			80	°C
			-40	°F				176	°F

\*1 At 23±5°C (Initial Performance Data)

\*2 Each value is typical.

## Mechanical specifications

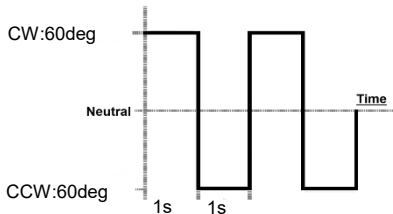
Item	Specification						Remarks
Outer Dimension	48.0	×	21.0	×	51.0	mm	See below Outer Dimension
	1.89	×	0.83	×	2.01	inch	
Weight	127					g	with Horn and screws without cables
	4.48					oz	
IP Code	IP67					Waterproof and Dustproof	
Case Material	Upper		Aluminium			Surface : Anodizing	
	Middle		Aluminium			Surface : Anodizing	
	Bottom		Aluminium			Surface : Anodizing	
Gear Set Material	Steel					Surface : Hardening treatment	
Gear bearing	8				ball bearing	Assembled to the output shaft	
Output Shaft	Serration S6L					Size: φ6mm, 25 teeth	
Radial load	100				N	Load position : Refer to Outer Dimension	
Position Sensor	Magnetic Encoder						
Motor Type	Brushless DC Motor						
MTTF *1	Operating time *2 (Inquire for the test report)		1,000	h	Operating Condition <ul style="list-style-type: none"> <li>at 28.0V</li> <li>±60°, 0.5Hz sweep</li> </ul> Test Condition <ul style="list-style-type: none"> <li>Load : Rated Torque (Powder Brake)</li> </ul>		
			1,800,000	cycle	<u>Angle Command Value</u>  <p>CW:60deg Neutral CCW:60deg 1s 1s</p>		
Vibration Resistance *1	Operating time *2 (Inquire for the test report)		300	h	Operating Condition <ul style="list-style-type: none"> <li>at 28.0V</li> <li>±60°, 0.5Hz sweep</li> <li>No-Load</li> </ul>		
					<u>Test Condition(sine wave)</u> <ul style="list-style-type: none"> <li>Frequency: 10 to 500Hz (sweep 1oct/min, amplitude limit 2mm)</li> <li>Acceleration : 300m/s<sup>2</sup></li> <li>Vibration axis : X,Y,Z</li> </ul>		
	Equivalent to MIL-STD-810H Method 514.8 (Annex E, Minimum Integrity)		Operating Condition <ul style="list-style-type: none"> <li>at 28.0V</li> <li>±60°, 0.5Hz sweep</li> <li>No-Load</li> </ul>		<u>Test Condition (Random wave)</u> <ul style="list-style-type: none"> <li>Refer to MIL-STD-810H Method 514.8</li> <li>Company internal test</li> </ul>		

\*1 At 23±5°C (Initial Performance Data) Each values are measured values and are not guaranteed values.

\*2 This test is currently undergoing continuous measurement.

# Outer Dimension

( unit : mm )

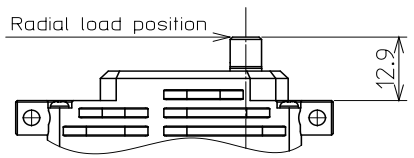
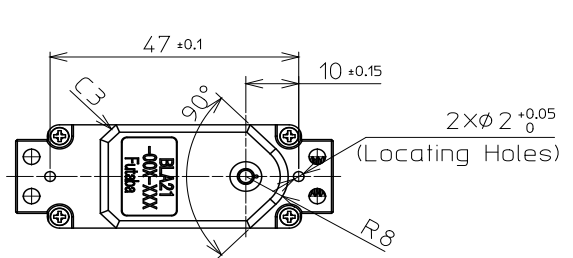
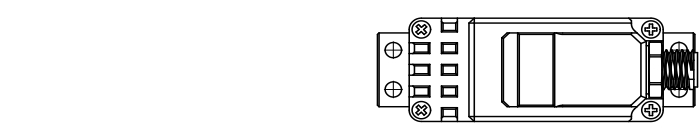
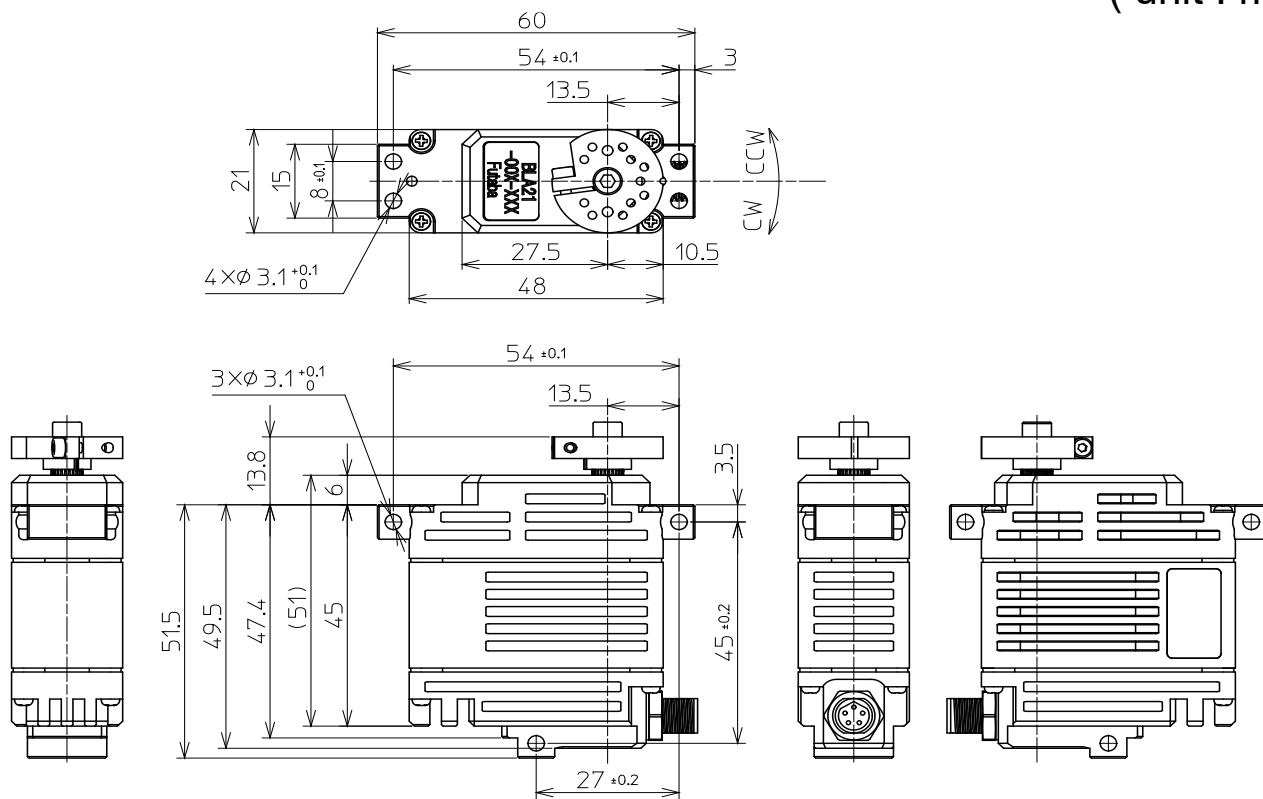

Without Servo Horn

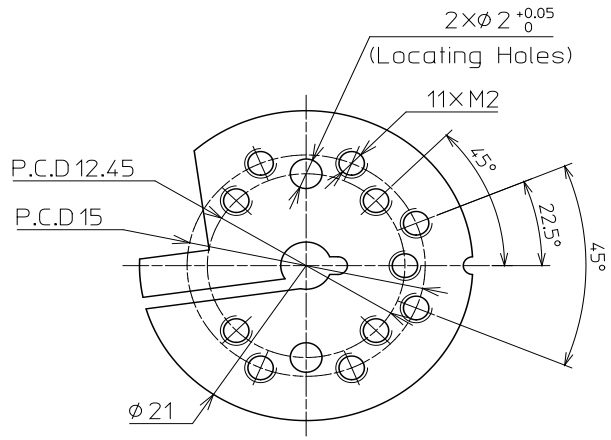

Servo Horn

## OUTPUT SHAFT

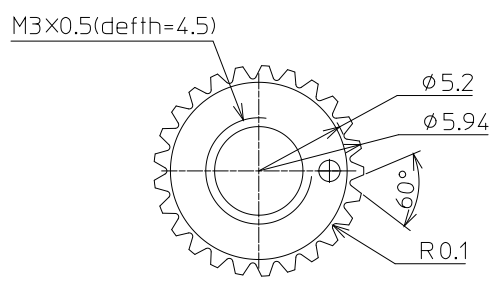
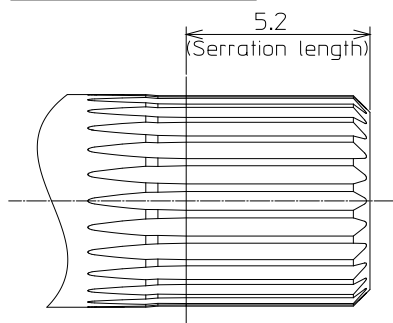

### Sarretion Size

Standard Diameter :  $\Phi 6$   
 Angle :  $60^\circ$   
 Tooth : 25

# Specifications for PWM signals

Item		Specification			Remarks		
Communication Interface				Signal Voltage HIGH:V	max	5.0	V
					min	2.0	V
				Signal Voltage LOW:V	max	0.45	V
					min	0.0	V
				Frame Rate:T	14.25		ms
Pulse Wide:Td	CW	2,120		μs			
	Center	1,520					
	CCW	920					
<p>If the high level voltage exceeds 5.0V, the servo may be damaged.                      If you use an RC device as a signal source, please pay attention to the voltage level of the PWM signal.</p>							
Operating Mode (PWM) + :CW - :CCW (Turn direction reversible) <sup>*1</sup>	Angle control (Absolute)	Rotation Angle	Default	Max	2,120μs	The travel ends are ±60° (default) with a pulse of 1,520 ± 600μs, where the input width is 600μs centered at a neutral of 1,520μs. The travel ends can be adjusted from ±60° to ±180° using the CANBUS line and the Futaba program tool. Both the neutral (1,520μs) and input width (600μs) can be set within ranges of 100 to 10,000μs and 10 to 10,000μs, respectively.	
			+60.0°	+180.0°			1,520μs
			Neutral 0°				920μs
			-60.0°	-180.0°			
	Angle control (Extended)	Rotation Angle	+360.0°		2,120μs		
			Neutral 0°		1,520μs		
			-360.0°		920μs		
	Speed control	Max Speed	+600	min <sup>-1</sup>	2,120μs		
			0		1,520μs		
-600			920μs				
This mode is for applications requiring continuous servo rotation. The speed can be set within ±600min <sup>-1</sup> using the CANBUS line and the Futaba program tool. Refer to "Speed with no load (Speed control mode)" for speed variations.							

\*1 Based on the top surface of the servo(the side with the nameplate).

## Specifications for CAN BUS signals

Item		Specification				Remarks		
Communication Interface		CAN BUS				Protocol :	DroneCAN v1	
						Baud Rate :	1	Mbps
						Sample Point:	87.5	%
						NodeID:	1	~
Operating mode (CAN BUS)	Angle control (Absolute)	-180.0	~	+179.9	°	The position within this range is absolute and can be recognized by the servo even after power-off. The position commands within this range are uniquely identified. For accuracy, see "Speed with no load (Speed control mode)". Resolution is 0.1°.		
	Angle control	-36,000,000.0	~	+36,000,000.0	°	The servo can accept position commands over 360°, but will lose multi-turn information when switched off, recognizing only the absolute position within 360°. Resolution is 0.1°.		
	Speed control	-300	~	+300	min <sup>-1</sup>	This mode is for continuous servo rotation, with speeds ranging within 300min <sup>-1</sup> . Speed settings can be adjusted via CANBUS and a Futaba program tool. Refer to "Speed with no load (Speed control mode)" for actual speed details.		
	Torque control	-100	~	+100	%	Maximum torque at 28.0V supply voltage is 100%. Refer to "Max Torque".		

# Connector specifications

Item		Specification		Remarks	
Cable		Shielded Cable(Detachable)		400	mm
				15.75	inch
Cable bending radius		78	mm		
Connector	Manufacture	ODS Electronics Co., Ltd.			
	Type	MMEPM05MCC-SHS7001			
	Matching	BE0010 or BE0011		Futaba Support Product Code	
Pin Assignment (BLA21-28U-A02)		Pin No.	Assignment	Cable Color	
		①	Battery(+)	Brown	
		②	Battery(-)	White	
		③	CAN-H	Blue	
		④	CAN-L	Black	
		⑤	Case Shield Line	Drain	
Pin Assignment (BLA21-28U-AB2)		Pin No.	Assignment	Cable Color	
		①	Battery(+)	Brown	
		②	PWM	White	
		③	CAN-H	Blue	
		④	CAN-L	Black	
		⑤	Battery(-) and Case Shield Line	Drain	
Pin Layout					

## Model name system

